

# BIRD JOLT

PATENT PENDING

*Flat Track*

**NEW &  
IMPROVED!**



Bird Jolt Flat Track (patent pending) is a low profile, electrical track system which produces a mild electrical jolt when birds land on it...thus changing their habits quickly!

The New & Improved Bird Jolt Flat Track uses stainless steel knitted wire mesh, in a continuous "tube-in-tube" stocking design. The Knitted design uses a single strand of higher gauge wire. This allows for greater conductivity, strength and reliability.

Bird Jolt Flat Track's copper mesh is resistant to corrosion and highly resistant to alkalis and acidic environments.

## Features & Benefits

- Patent Pending "Anti-Arcing" Design Means the Ultimate in Safety!
- Lightweight Flexible U.V. Stabilized PVC - One 100ft. Roll Only Weighs 15 lbs!
- Available in Complete 100 ft. Kits! All Necessary Hardware Included - No Need to Purchase Separate Connections and Wire!
- Glue Troughs Mean Better Adhesion!
- Available in 4 Colors: Grey, Stone, Black and Terra Cotta!
- Lowest Profile / Virtually Invisible! Only 1/4" High at the Highest Point!
- Snap Fit Connections Make it Super Easy to Install!
- Lowest Cost - GUARANTEED!

Easy to Carry -  
Easy to Dispense  
Box!



**Super Easy to Cut...  
Like Butter!**



Available in four colors - Grey,  
Black, Stone & Terra Cotta!



**BIRD•B•GONE™**  
1-800-392-6915

www.birdbgone.com • email: nobirds@birdbgone.com

# BIRD JOLT

PATENT PENDING

*Flat Track*

**Bird Jolt  
FlatTrack Means  
NO Birds!**

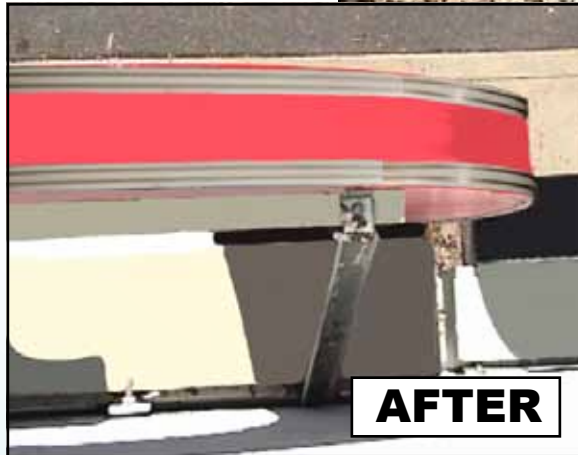
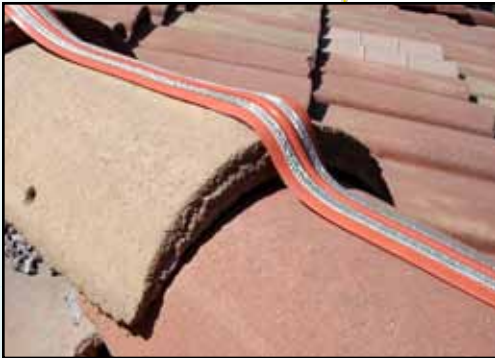

**Conforms to Any  
Geometric Surface!**

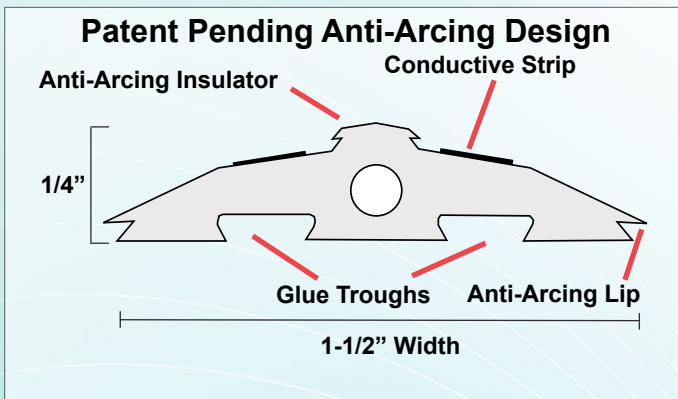

**Easily Turns the Corner with new "Snug Fit" Corner Connector.**



**Easy to Install "Snug Fit" Connectors!  
Water Tight / Weatherproof!**

## Recommended Track Spacing

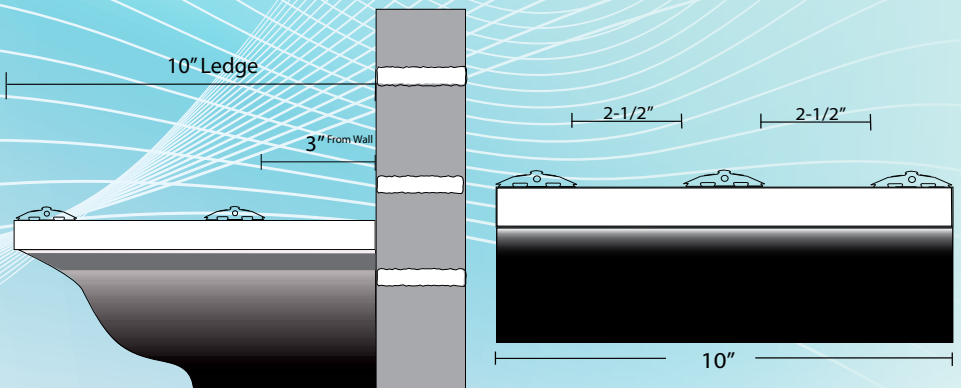

**BIRD•B•GONE™**  
INC.  
**1-800-392-6915**

[www.birdbgone.com](http://www.birdbgone.com) • email: [nobirds@birdbgone.com](mailto:nobirds@birdbgone.com)