

MODELS 316 / 324 / 332 FEATURES / INSTRUCTIONS

BULK • CARTRIDGE • SAUSAGE LOADERS

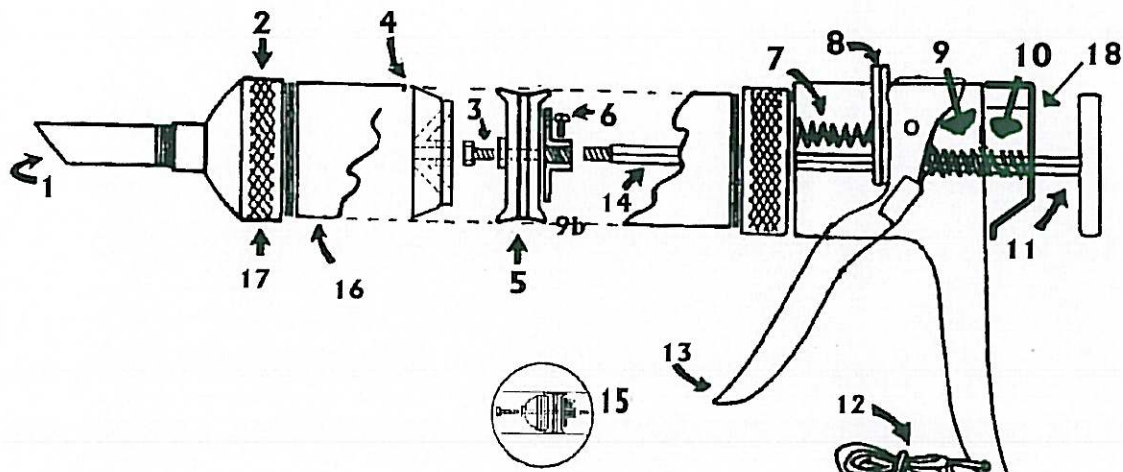

- Fully equipped to be used for bulk, cartridge and sausage packs with no other parts or kits needed.
- Available in capacities of 16 oz., 24 oz., and 32 oz.
- Patented E-Z Thrust® Mechanism delivers powerful 10:1 thrust with little effort.
- Designed to fit your existing nozzles and accessories to maximize your prior investment.
- Loaded with many time and money saving features without extra charge.
- Replacement parts available for easy repair*



- | | |
|--|--|
| 1. Interchanging Nozzle | 10. Recoil Springs |
| 2. Extra Deep Knurling on Front & Back Cap | 11. Solid "T" Bar |
| 3. Plunger Bolt | 12. "D" Ring & Wriststrap |
| 4. Floating Cup for Sausage | 13. Extra Long Pistol Grip Trigger |
| 5. Dual Leather Cups | 14. Hex Push Road |
| 6. Push Disk & Set Screw | 15. Multi-Chemical Resistant Hytrel Cups |
| 7. Front Springs | 16. Extra Heavy Duty Steel Barrel |
| 8. Dual Friction Plate | 17. Internal Gasket |
| 9. Recoil Springs | 18. Gripping Plate |

*See next page for how to rebuild your bulk loader

LOADING INSTRUCTIONS

To Use as a Bulkloader:

If you are using a follow plate: Remove the front cap and wet the end of the bulk loader with water or a release agent. Also spray or put water into the gun chamber to lubricate the interior. Attach the bulk loader to the follow plate (Newborn Model FPT-05 or FPT-02), lock the thumb release and pull the load slowly until the gun is full. Newborn's neoprene follow plates use the air tight "O" ring. There is no need to screw barrel into follow plate to lock.

If you are not using a follow plate: Place the end of the bulk loader into the material about 2-3 inches and pull back the rod to bring the material into the gun. Scrape the material off of the gun to make sure the gun is clean.

Clean Up: At the end of your job, put remaining caulk back into the pail and seal it. Place the gun into a pail of water with the front cap removed and pull the rod back and forth. Continue doing this until the gun is clean. Spray a light lubricant (like WD40) into the gun chamber both in front of and behind the leather cups. Leave gun open until it is dry and wipe the exterior of the gun with light oil.

If the gun will not fill, the leathers may be worn or dried out. If this is the case, place the end of the gun into warm water and keep pulling on the rod until water is pulled into the gun. Important, leathers will lose shape if soaked in water for too long so avoid soaking the leathers in water too long.

To Use with Sausage Pack:

1. Pull the piston rod all the way backward.
2. Remove the front cap.
3. Insert the Floating Cup (part No. HFC-81) into the barrel. Must be evenly inserted. Push down the Floating Cup with your sausage pack (unopened) all the way to the end. If you would like to attach this cup permanently, remove the top leather cup and replace it with the Floating Cup and bolt it on with the bolt contained in the HFC-81 package.
4. Cut open your sausage pack and close the front cap.
5. Slowly squeeze trigger until you feel the Floating Cup snap in the leather cup.

To Use with Cartridge:

1. Take the front cap off.
2. Loosen the bolt holding the leather cups in place.
3. Remove the leather cups.
4. Cut nozzle to preferred size and load cartridge into barrel.
5. Screw on front cap tightly by hand to assure proper seal.
6. Puncture seal through the plastic nozzle opening.

To Rebuild Your Bulk Loader:

Newborn bulk loaders come with a special heat-treated rod that is made to stand up to heavy duty use. Because the rod is so hardened, the dual friction plate (part #8) may wear out, causing excessive play in the trigger. When this happens, refer to the instructions below:

1. Remove barrel and push disk (part #6). Pull back rod just far enough to be able to remove dual friction plate (part #8).
2. After replacing dual friction plate with a new one, push rod forward through the hole in the friction plate.
3. Replace front spring (part #7) to original position.
4. Reassemble push disk and barrel.